



2027 UCI Handlebar restrictions for Track Cycling

Starting **January 1st 2027**

- The minimum width outside to outside of the drop of your handlebar cannot be narrower than 350mm. This overall width of 350mm must also be maintained for 2/3rds of the overall handlebar's drop. For example, if your handlebar had a drop of 100mm then it must maintain that overall 350mm width for 67mm of its drop before it can flair inwards to a maximum of 80mm from the end of the drop.
- The maximum width of the top tubing of the handlebar can't exceed 65mm.

This rule change unfortunately means that a large percentage of the handlebars being used by Canadians will be illegal because of this new UCI rule and not usable in any UCI approved race including Nationals.

To clarify, the following handlebars are the most common among the Canadian team and will unfortunately be illegal moving forward:

- The Velobike SKAT handle bar in the 300mm and 325mm width will be illegal. The 300mm width is too narrow. The 325mm width flairs in too quickly and does not follow the 2/3rds requirement.
- The Velobike Altias handlebar in all sizes will be illegal because the top section of the handlebar exceeds 65mm.
- WXR BTC 3.0 will no longer be legal. It is too narrow.
- WXR MTC1.0 will no longer be legal. It is too narrow.

There are other brands and models of handlebars in use that will also be illegal. Please check your equipment. If it is illegal and you plan to race at Nationals or other international races please find different handlebar well in advance of the start of 2027 season.

Following is a quick list of alternative UCI legal handlebars to look at that are currently available on the market.

Endurance handlebars:

- [Vision Metron Track Handle Bars](#)
- [Bunch Bars - Velodrome Shop](#)
- [Velobike SKAT 350 mm only!!!!](#) **Only the 350mm size will be legal**

Sprint handlebars:

- [Velobike - Vector Handle bar](#)

Cycling Alberta
cyclingalberta.com
11759 Groat Road
Edmonton AB T5M 3K6
1-877-646-2453



This is a link to an article that Velobike published recently with some useful information and diagrams helping explain the new rule changes: [Velobike Article Explaining UCI Rule Changes](#)

This is a link to the UCI's official technical document for all equipment rules: [UCI Equipment Regulations](#)

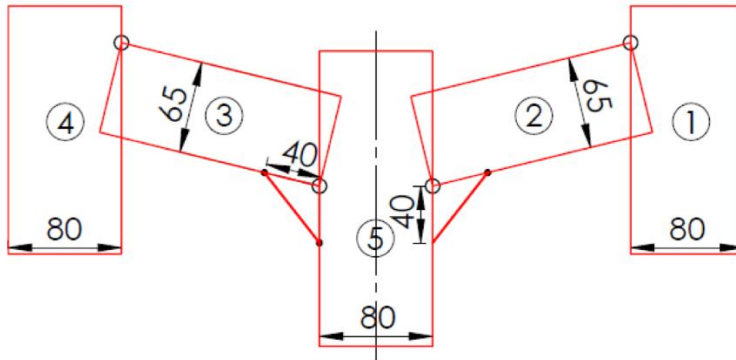

Structure (1.0) Track

Above Diagram: Maximum width of handlebars

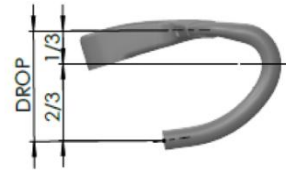
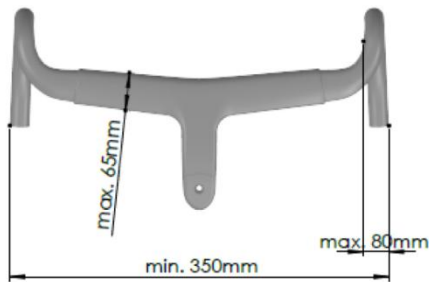

Figure 37 Illustration of the handle area that must comply with the minimum overall width of 350 mm

Above Diagram: Minimum width of handlebars

Cycling Alberta

cyclingalberta.com
11759 Groat Road
Edmonton AB T5M 3K6
1-877-646-2453